



STANDARD CONSTRUCTION

BODY:
26 GAUGE ASTM A-653 HOT-DIPPED
GALVANIZED STEEL SHEET

STANDARD SIZES:

MODEL	LENGTH	WIDTH	DEPTH	GAUGE	QTY.
WSWC10	10"	3 1/4"	10 1/4"	26	1
WSWC12	12"	3 1/4"	10 1/4"	26	1
WSWC14	14"	3 1/4"	10 1/4"	26	1

FEATURES

26 GAUGE GALVANIZED STEEL PROVIDES EXCELLENT CORROSION RESISTANCE AND LONGEVITY.

BACKDRAFT DAMPER AND EXPANDED METAL SCREEN INCLUDED.

DISCHARGE HOOD AREA EQUAL OR GREATER THAN INLET PIPE AREA.

FLANGED BASE PROVIDES FOR GOOD VENT-TO-WALL CONTACT AND AN EASY CAULKING SURFACE.

LONG GALVANIZED NECK ALLOWS FOR EASY UNION THROUGH WALLS TO INTERIOR DUCTS.

OPTIONS: CUSTOM SIZES AVAILABLE.

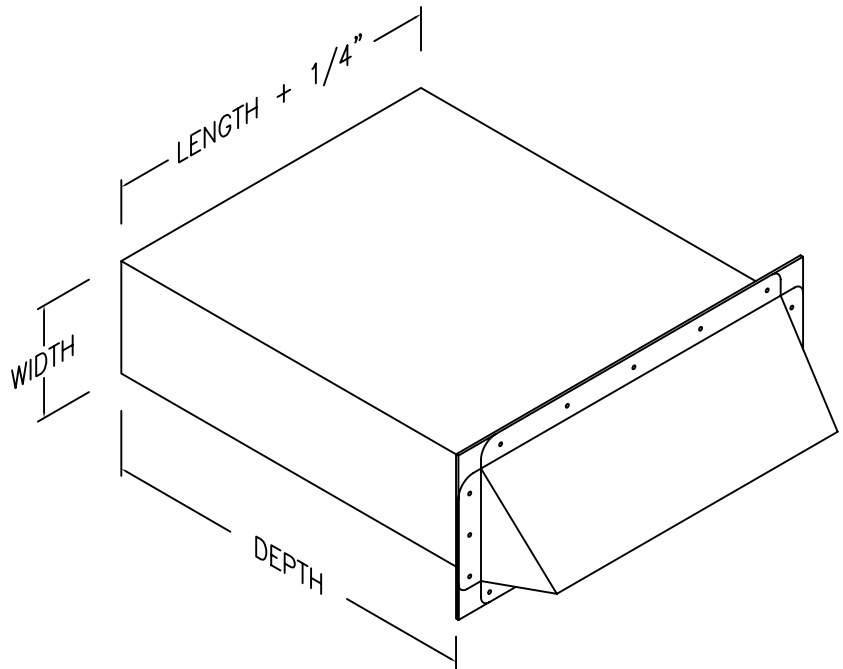

JOB NAME:
LOCATION:
ARCHITECT:
ENGINEER:
CONTRACTOR:
CONTACT MIAMI TECH INC. FOR ADDITIONAL INFORMATION OR WITH SPECIAL REQUIREMENTS. 3611 NW 74TH ST MIAMI, FL 33147 PHONE: 305-693-7054 FAX: 305-693-6152 WEB: WWW.MIAMITECH.COM EMAIL: SALES@MIAMITECH.COM

WSWC

WALL STACK SIDE WALL CAP
PRODUCT SPECIFICATIONS

NOTE: ALL DRAWINGS SUBJECT TO CHANGE WITHOUT PRIOR NOTICE.



DRAWN BY: AF	DATE: 10/31/07	SCALE: NOT TO SCALE
CHECKED BY: IG	DATE: 10/31/07	REVISION: IG

DRAWING NO. WSWC