



STANDARD CONSTRUCTION

BODY:
28 GAUGE GALVANIZED STEEL SHEET
INSULATED WITH R4 OR R6 BLACK FIBERGLASS DIFFUSER BOARD

OPTIONS:
CUSTOM SIZES AVAILABLE

STANDARD SIZES:

W X H X D
8 X 4 X 4/5/6
8 X 8 X 6/7/8
10 X 8 X 6/7/8/10
10 X 10 X 6/7/8/10
12 X 6 X 6/7/8
12 X 8 X 7/8/9/10
12 X 12 X 8/9/10
14 X 6 X 6/7/8
14 X 8 X 7/8/9/10

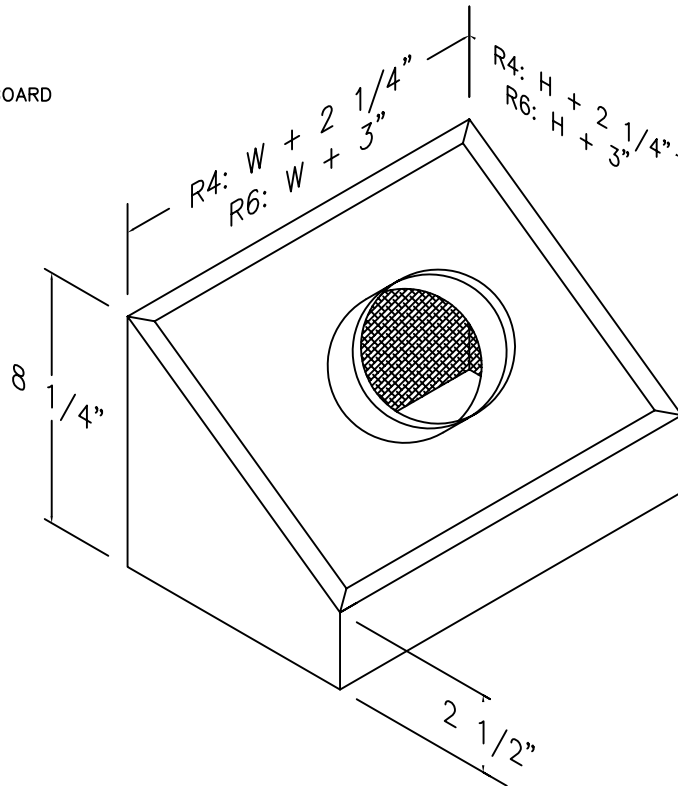

FEATURES

28 GAUGE GALVANIZED STEEL PROVIDES EXCELLENT CORROSION RESISTANCE AND LONGEVITY.

FULLY INSULATED BODY.

RIVETED SEAMS FOR ADDED STRENGTH.

ALSO AVAILABLE AS A FLANGED UNIT. (SMTB)

METAL BACKED REGISTER BOXES ARE PRE-FIT TO THE COLLAR SIZE OF YOUR CHOICE.

BLACK DIFFUSER BOARD COATED WITH EPA-REGISTERED, ANTI-MICROBIAL, PROTECTIVE ACYRLIC AGENT ALONG AIR STREAM SIDE.

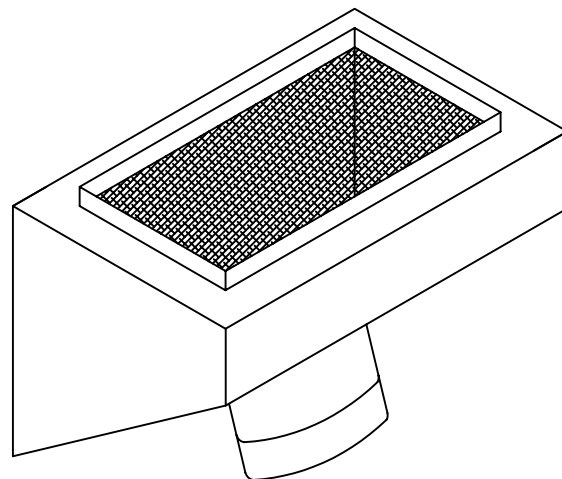

JOB NAME:
LOCATION:
ARCHITECT:
ENGINEER:
CONTRACTOR:
CONTACT MIAMI TECH INC. FOR ADDITIONAL INFORMATION OR WITH SPECIAL REQUIREMENTS. 3611 NW 74TH ST MIAMI, FL 33147 PHONE: 305-693-7054 FAX: 305-693-6152 WEB: WWW.MIAMITECH.COM EMAIL: SALES@MIAMITECH.COM

R4SMTU, R6SMTU

METAL BACKED
UNFLANGED SLANTED REGISTER BOX
PRODUCT SPECIFICATIONS

NOTE: ALL DRAWINGS SUBJECT TO CHANGE WITHOUT PRIOR NOTICE.



DRAWN BY: AF	DATE: 08/24/07	SCALE: NOT TO SCALE	DRAWING NO. R4SMTU/R6SMTU
CHECKED BY: IG	DATE: 08/24/07	REVISION: 1	