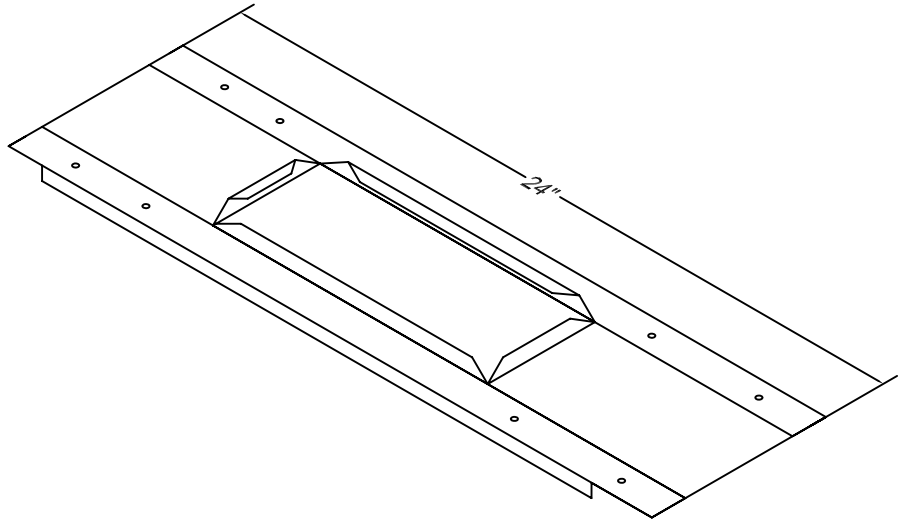

STANDARD CONSTRUCTION

MATERIAL:
28 GAUGE ASTM A-653 HOT-DIPPED GALVANIZED
STEEL SHEET

STANDARD SIZES:

Part #	Opening Size	Overall Length
PF0804-24	8 x 4"	24"
PF1004-24	10 x 4"	24"
PF1006-24	10 x 6"	24"
PF1204-24	12 x 4"	24"
PF1206-24	12 x 6"	24"
PF1404-24	14 x 4"	24"
PF1406-24	14 x 6"	24"

FEATURES

28 GAUGE GALVANIZED STEEL PROVIDES
EXCELLENT CORROSION RESISTANCE AND
LONGEVITY.

OPTION: CUSTOM SIZES AVAILABLE.

JOB NAME:
LOCATION:
ARCHITECT:
ENGINEER:
CONTRACTOR:
<p>CONTACT MIAMI TECH INC. FOR ADDITIONAL INFORMATION OR WITH SPECIAL REQUIREMENTS.</p> <p>3611 NW 74TH ST MIAMI, FL 33147 PHONE: 305-693-7054 FAX: 305-693-6152</p> <p>WEB: WWW.MIAMITECH.COM EMAIL: SALES@MIAMITECH.COM</p>

PF

 PLASTER GROUND FRAME
PRODUCT SPECIFICATIONS

NOTE: ALL DRAWINGS SUBJECT TO CHANGE WITHOUT PRIOR NOTICE.