

STANDARD CONSTRUCTION

26 GAUGE ASTM A-653 HOT -DIPPED GALVANIZED STEEL

COLLAR: 26 GAUGE HOT DIPPED GALVANIZED STEEL

INSULATION:
1"-R4 DIFFUSER BOARD

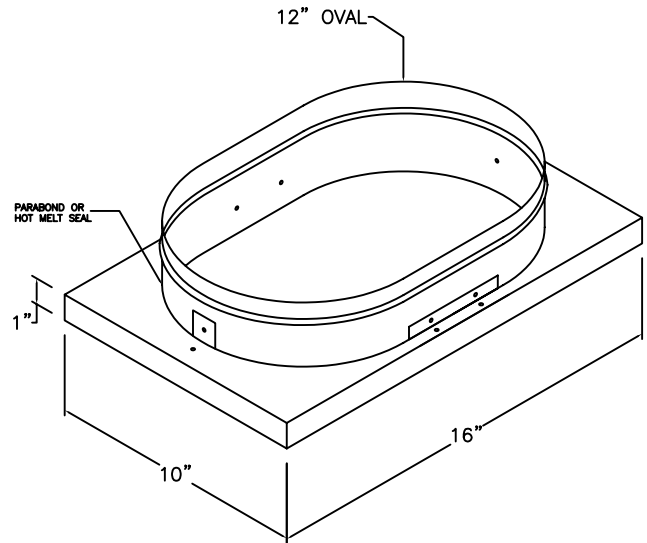

STANDARD SIZE:

10" Wide x 16" Long x 1" Tall. 12" Collar.

FEATURES

SET OF TWO IDENTICAL TAKE-OFFS (ONE SUPPLY AND ONE RETURN)

COLLAR INSTALLED WITH EXPANSION LOCK AND THEN SEALED AIR TIGHT WITH HOT MELT GLUE OR PARABOND ALUMINUM ADHESIVE.

DIFFUSER BOARD COATED WITH EPA-REGISTERED, ANTI-MICROBIAL, PROTECTIVE ACRYLIC AGENT ALONG AIR STREAM SIDE.

FOR OTHER SIZES, REFER TO MODEL ICPRTCPU SPECIFICATIONS FOR OPTIONS.

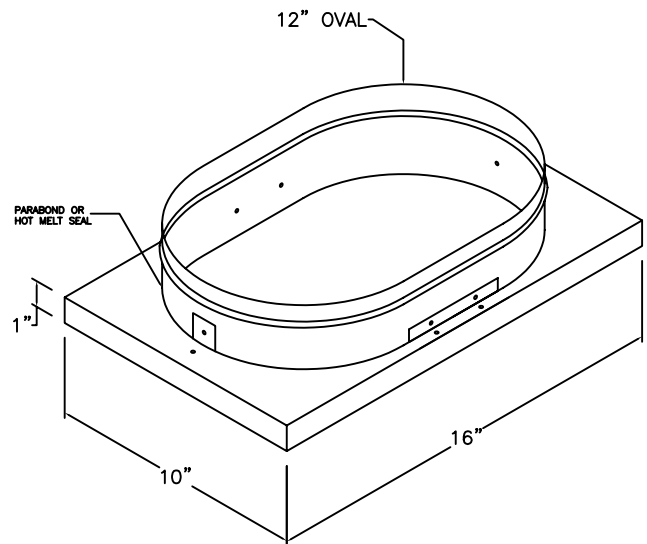

JOB NAME:
LOCATION:
ARCHITECT:
ENGINEER:
CONTRACTOR:
<p>CONTACT MIAMI TECH INC. FOR ADDITIONAL INFORMATION OR WITH SPECIAL REQUIREMENTS.</p> <p>3611 NW 74TH ST MIAMI, FL 33147 PHONE: 305-693-7054 FAX: 305-693-6152</p> <p>WEB: WWW.MIAMITECH.COM EMAIL: SALES@MIAMITECH.COM</p>

ICPTCPU12SR

ICP TAKE-OFF COLLAR FOR PACKAGE-UNIT
SUPPLY AND RETURN
PRODUCT SPECIFICATIONS

NOTE: ALL DRAWINGS SUBJECT TO CHANGE WITHOUT PRIOR NOTICE.

DRAWN BY: AV	DATE: 06/16/2010	SCALE: NOT TO SCALE	DRAWING NO. ICPTCPU12SR
CHECKED BY: IV	DATE: 11/15/2010	REVISION: 02	